

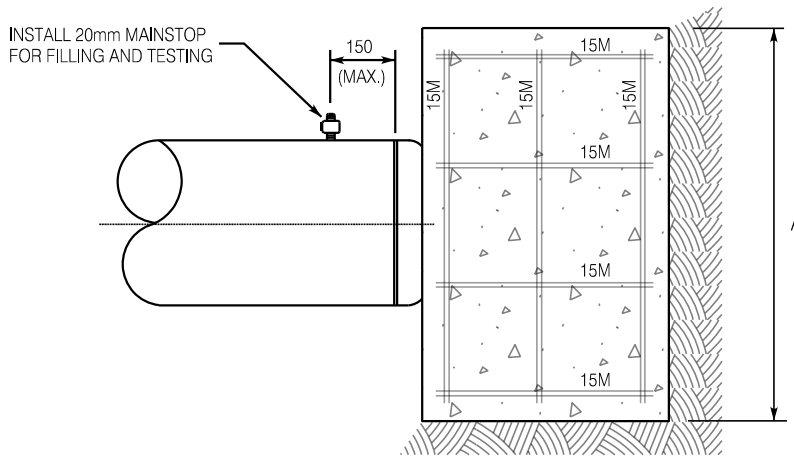

**PLAN VIEW**



**SIDE ELEVATION**

**NOTES:**

1.  DENOTES UNDISTURBED GROUND.
2. ALL CONCRETE TO BE 32 MPa.
3. MINIMUM COVER OF CONCRETE OVER REINFORCING TO BE 75mm.
4. ALL REINFORCING STEEL TO BE GRADE 400.

		PIPE DIA. (mm)					
		400	450	500	600	750	900
MIN. DIM. (mm)	A	950	1100	1200	1400	1800	2100

City of Hamilton  
Public Works Department

**CONCRETE THRUST BLOCK  
FOR 400mm TO 900mm DIA. D.I. WATERMAINS**

DIMENSIONS SHOWN ARE IN MILLIMETRES  
UNLESS OTHERWISE NOTED (N.T.S.)

DATE  
June 2025

REV No  
2

FORMERLY: RWS-411

HAMILTON STD No

**WM-204.09**