

Solid Waste Collection Design Guidelines for Developments



CITY OF HAMILTON
JUNE 2015

Table of Contents

| | |
|--|----|
| 1. Introduction & General Information | |
| 1.1 Purpose..... | 1 |
| 1.2 Background..... | 1 |
| 1.3 Definitions..... | 2 |
| 2. Review & Approval Process | |
| 2.1 Eligible & Ineligible Properties | 6 |
| 2.2 General Requirements | 6 |
| 2.3 Development Application Approval Requirements | 7 |
| 2.4 Requirements for On-site Collection on Private Property | 7 |
| 2.5 Private Road Application & Agreement..... | 8 |
| 3. Requirements for Residential Properties with a Maximum of 5 Units | |
| 3.1 General Considerations | 8 |
| 3.2 Container Storage/Collection Area Requirements | 8 |
| 4. Requirements for Multi-residential Buildings | |
| 4.1 General Considerations | 9 |
| 4.2 Diversion Container Requirements | 10 |
| 4.3 External Storage/Collection Container Requirements | 10 |
| 4.4 Internal Container Storage | 11 |
| 4.5 Bin Collection Area Requirements | 11 |
| 4.6 Maintenance Requirements for Access | 12 |
| 5. Requirements for Eligible Institutional & Municipal Developments | |
| 5.1 Places of Worship | 12 |
| 5.2 Schools | 12 |
| 5.3 Municipally Owned or Leased Properties | 13 |

| | | |
|-----|---|----|
| 6. | Requirements for Other Properties | |
| 6.1 | Mixed Use Commercial-Multi-residential Buildings with 6 or More Residential Units | 14 |
| 6.2 | Commercial Properties with a Maximum of 3 Floors & Commercial Properties In Special Policy Areas | 14 |
| 6.3 | Industrial Developments, Shopping Centres, Commercial Properties with 4 or More Floors & Institutions | 15 |
| 7. | Commencement of Collection Service | 15 |

Appendices

| | | |
|----|-------------------------------------|----|
| A. | Bin Container Specifications..... | 16 |
| B. | Blue and Green Cart Dimensions..... | 17 |
| C. | “T” Turnaround Specifications..... | 18 |
| D. | Private Road Application..... | 19 |
| E. | Private Road Agreement..... | 21 |

1. Introduction & General Information

1.1 Purpose

The Solid Waste Collection Design Guidelines for Developments (“the design guidelines”) provides direction as to how developments are to be designed to provide safe and efficient movement for Waste Collection Vehicles. City of Hamilton (the “City”) Solid Waste Collection Service includes Garbage, Recycling, Organics, Leaf and Yard, as well as Bulk Waste. The requirements for Collection Service are taken into account during the design and development process of all eligible developments interested in receiving municipal Waste Collection Service.

The design guidelines serve as a tool to assist developers, architects and planners in the property development stage, in order for Collection Vehicles to access the property safely.

1.2 Background

The City provides Waste Collection Service to a variety of properties deemed eligible as per By-law 09-067, as amended: Solid Waste Management By-Law. This By-law provides and regulates the Waste Management System for the City. For clarification of all terms used in this document, please refer to Section 1.3 Definitions.

The Operations Support Team of the Public Works Department reviews development applications and provides comments to the Planning and Economic Development Department. Planned changes to Waste Collection location, method of collection, structural expansions and change of property usage are reviewed. The guidelines are based on the following principles:

- The Environmental Protection Act (EPA), the Waste Diversion Act, the Environmental Assessment Act and the Planning Act are all key laws that affect waste and recycling activities in Ontario; and
- The Guiding Principles of the City’s Solid Waste Management Master Plan Recommendations (2012) “*The City of Hamilton shall lead and encourage the changes necessary to adopt the principle of Waste Reduction*”. User friendly and promptly accessible diversion programs for all residents is a priority for the City of Hamilton.

The General Manager reserves the right to designate the type of collection to be provided and to prescribe all requirements associated with the different collection methods, including access and storage. In addition to the design requirements, the By-law as well as all other applicable By-laws and legislation shall be followed in order to be eligible for Waste Collection Service. Failure to comply with any of the criteria outlined in this document may result in suspension of Collection Service.

1.3 Definitions

The following definitions apply to the design guidelines:

Bin Collection: the collection of Garbage from a Bin Container by a forklift packer truck.

Bin Container: a receptacle made of metal or plastic used for the deposit of Waste and emptied by a forklift packer truck.

Blue Cart: a large blue reusable plastic receptacle (up to 360 litres) with wheels used for the collection and storage of Recyclable Materials.

Bulk Waste: large household items such as carpet, mattresses, furniture, etc. as defined by By-law 09-067, as amended.

By-law: the City of Hamilton's Solid Waste Management By-law No. 09-067, as amended and as it exists from time to time, or any successor by-law.

City: the geographical area of the City of Hamilton.

Collection Day: the specific day(s) of the week and/or date(s) for the collection of Waste, prescribed by notice given by the City to owners and occupants of Eligible Properties.

Collection Operator: staff retained to collect, remove and transport Waste, whether employed by a contracted service provider or directly by the City.

Collection Service: either Curbside Collection or Bin Collection provided by the City directly or through a private operator under contract with the City to provide Collection Service.

Collection Vehicle: a vehicle operated for the collection and transport of Waste.

Common Collection Pad: a concrete or asphalt or similar hard-surface pad for waste to be placed out for collection.

Curbside Collection: the system of collection of Garbage, Recycling, Organics, Bulk Waste and/or Leaf and Yard Waste placed in approved containers.

Development Application: an application submitted through the Planning & Economic Development Department for review and comment by City staff.

Dwelling Unit: a room or suite of rooms used or intended to be used by one or more persons and to which an independent entrance is provided from outside the building or from a common interior hallway, vestibule or stairway but does not include a room or a suite of rooms in a lodging house, long-term care facility, hospital, hotel or residential care facility all as defined in the City's zoning by-laws.

Eligible Property: a property that is eligible to receive Waste Collection Service pursuant to the By-law, including:

- i. single detached dwellings and multiple dwellings with a maximum of five Dwelling Units, including street townhouse dwellings but excluding block townhouse complexes;
- ii. multiple dwellings with six or more Dwelling Units, including block townhouse complexes and trailer parks;
- iii. other residential property, including lodging houses and residential care facilities in residential neighbourhoods;
- iv. commercial properties, **excluding** commercial properties with four or more floors, regional shopping centres, community shopping centres, neighbourhood shopping centres and strip malls;
- v. places of worship, **except** uses that are accessory or ancillary to the place of worship;
- vi. schools for the collection of Organic Waste and Recyclable Material only;
- vii. City-owned or City leased property used for the purpose of administering the City or providing City service.

Garbage: the discarded material that is set out for municipal Garbage collection as defined in the By-law 09-067, as amended.

Garbage Container: a rigid, reusable Container with a volume less than 135 litres or a non-returnable plastic Garbage bag capable of being closed or tied.

General Manager: the General Manager of Public Works for the City or their duly

appointed designate, or successor.

Green Cart: a large green reusable plastic receptacle with wheels used for the collection and storage of Organics.

Ineligible Property: any property within the City that is not defined as an Eligible Property or where the General Manager has discontinued or refused Waste Collection Service under subsection 7.1(d) of the By-law 09-067, as amended.

Leaf and Yard Waste: leaves, grass, weeds, garden hedge and tree trimmings, branches, brush, house and garden plants.

Lodging House: any house or other building or portion of it in which persons are lodged, but does not include a hotel, hospital, long-term care home, home for the young or institution if it is licensed, approved or supervised under a general or special Act other than the *Municipal Act, 2001*.

Multi-residential Building: a building or part thereof containing six or more dwelling units but does not include a street townhouse dwelling or semi-detached dwelling.

Municipal Hazardous or Special Waste (MHSW): any household product, material or item labelled as corrosive, toxic, reactive, explosive or flammable and which is accepted under the City's Household Hazardous Waste program, as further defined in the By-law 09-067, as amended.

On-site Collection: the collection of waste on Private Property or Public Property.

On-site storage room: a room meeting all *Ontario Building Code and Fire Code* regulations (as amended) used to store waste until collection day.

Organic Waste or Organics: the animal or vegetable waste including, but not limited to kitchen, yard and other source separated organic waste material, **excluding** household pet waste, carcasses and sanitary products.

Pathological Waste: bandages, dressings, drugs, medicines, needles, poultices, syringes, vaccines, vials and other similar materials or substances which contain or could reasonably be expected to contain pathogenic bacteria or microorganisms or could reasonably be expected to be infectious, hazardous or dangerous; or, anything designated as Pathological Waste by O. Reg. 347 under the *Environmental Protection Act*.

Private Waste Hauler: an individual or corporation in the business of transporting

waste that is not operating under contract to the City.

Private Road: a road or other form of laneway over which vehicular access is possible but which is not maintained or assumed by the City.

Private Road Agreement: an Agreement between the property owner, ruling board, or authorized representatives and the City concerning access and use of a Private Road for the on-site collection of Garbage, Recycling, Organics, Bulk Waste and/or Leaf and Yard Waste.

Recyclable Material or Recycling: the containers and/or the fibres as defined in the By-law 09-067, as amended.

Roadway: the part of the road that is used by vehicles and over which vehicles travel.

Semi-detached Dwelling: a single building containing two separate dwelling units.

Special Policy Area: means a downtown core area or a Business Improvement Area as defined by By-law 09-067, as amended.

Substantially Completed: the Collection Vehicles are able to travel safely without hindrance through a development site on a paved surface which can support the weight of a fully loaded Collection Vehicle.

Turning Radius: the smallest, circular area where a Collection Vehicle is capable of making a turn.

Waste: the Garbage, Recyclable Materials, Organics, Bulk Waste, Leaf and Yard Waste, Municipal Hazardous or Special Waste, Liquid Waste, Pathological Waste, and/or White Goods.

2. Review & Approval Process

2.1 Eligible & Ineligible Properties

The following note shall appear on the site plan for any property defined as an Eligible Property for Collection Service:

“This property is eligible for the collection of Garbage, Recycling, Organics, Bulk Waste and/or Leaf and Yard Waste through the City of Hamilton, subject to continuous compliance with requirements outlined in the City of Hamilton Solid Waste Management By-law 09-067, as amended, and Solid Waste Collection Design Guidelines for Developments.”

The following note shall appear on the site plan for any property defined as an Ineligible Property for Collection Service:

"This property is ineligible for the collection of Garbage, Recycling, Organics, Bulk Waste and/or Leaf and Yard Waste by the City of Hamilton. Collection of Waste shall be provided through a Private Waste Hauler(s). Recycling and Organics diversion is strongly encouraged.”

2.2 General Requirements

The City will provide Collection Service to Eligible Properties for Waste excluding Municipal Hazardous and Special Waste, Pathological Waste, Construction Material, Liquid Waste, Scrap Metal, White Goods, and any other unacceptable Garbage as defined in the By-law 09-067, as amended. The General Manager reserves the right to withhold or revoke Collection Service from any development that does not meet the requirements set out in this document, the By-law and any other applicable By-law or legislation. Eligible Properties are required to abide by quantity limits and set out requirements as per the By-law.

The same level of Collection Service shall be provided throughout the entire development. The City will not simultaneously provide Curbside Collection to some Dwelling Units and Bin Collection to others. In the event that there are particular Dwelling Units within a development that are inaccessible for Collection Vehicles, the developer or owner shall either redesign the development to allow the same accessibility for all Dwelling Units or arrange to provide private Waste Collection, at their own expense, for the entire development.

The City only provides Collection Service that complies with the provisions of the

Occupational Health and Safety Act (the “OHS Act”) and regulations. Subsection 104(1) of the OHS Act states that: “Every project shall be planned and organized so that vehicles, machines and equipment are not operated in reverse or are operated in reverse as little as possible.” Developers are required to submit designs which allow adequate space for Collection Vehicles to navigate through the property in a safe manner. A Private Road shall permit the continuous forward movement of Collection Vehicles, including the radius of a cul-de-sac turning circle.

Prior to the commencement of Collection Service, the developer or owner is responsible for the collection of all Waste from all occupied Dwelling Units, as well as common areas. Waste material generated by construction is not eligible for collection and shall be disposed of through a Private Waste Hauler at the expense of the developer or owner.

2.3 Development Application Approval Requirements

The following information is required to review Development Applications for Waste Collection Service:

- scale;
- type of developments/building;
- number of Dwelling Units and number of floors of each building;
- access and egress routes;
- illustration of the anticipated movement of the Waste Collection Vehicle through the building site;
- turning radius from the centre line;
- clear illustration of Garbage collection area(s); and
- waste storage facilities, including refuse and waste chute rooms to be located on each floor of vertical Multi-residential Buildings.

2.4 Requirements for On-Site Collection on Private Property

To receive Collection Service on a Private Road, the following specifications shall be met:

- access routes shall have a minimum width of 6 metres;
- a 13 metre turning radii from the centre line throughout the access routes;
- a minimum 18 metres straight head-on approach to the collection area at a level (+/-2%) and the same width as the collection area;
- where the preferred 18 metre head-on approach is not achievable, the collection area shall be designed to allow a Waste Collection Vehicle to drive forward onto

the site, collect the Waste and exit without the need to back up onto a municipal Roadway. A turnaround area allowing for a maximum three-point turn of not more than one truck length or a drive through access route are acceptable options for accommodating this requirement;

- the waste collection area(s) is constructed on private property with access to the municipal road that does not require the Collection Vehicle to back onto a municipal Roadway or back into a private property from a municipal Roadway;
- the road design shall accommodate continuous forward movement of Waste Collection Vehicles, including the radius of a cul-de-sac turning circle or hammer head as illustrated in Appendix C;
- the road base shall support a minimum of 35,000 kilograms;
- “No parking” signage shall be posted throughout;
- the development needs to be Substantially Completed; and
- the collection area(s), including the access and adequate manoeuvring space for the Collection Vehicle shall be provided exclusive of any on-site parking spaces as well as stored snow.

2.5 Private Road Application & Agreement

When municipal Waste Collection Vehicles are to travel on a private Roadway for the purpose of Waste Collection, an “Application for On-Site Collection of Municipal Solid Waste” (Appendix D) must be submitted to the City. Following approval of this application, an “Agreement for On-Site Collection of Municipal Solid Waste” (Appendix E) and a certificate of insurance shall be completed and submitted to the City prior to service commencement. The City and its contractors shall be noted as additional insured as per “Section 2.2 Insurance” of the Agreement.

3. Requirements for Residential Properties with a Maximum of Five (5) Units

3.1 General Considerations

Curbside Collection will be provided for all dwellings fronting on a municipal Roadway with a maximum of five (5) units.

The developer or owner shall contact the City by email wastemanagement@hamilton.ca or by telephone 905-546-CITY (2489) to request Waste Collection Service.

A site visit by Public Works staff may be required prior to the start of Collection Service.

3.2 Container Storage/ Collection Area Requirements

For each unit receiving Curbside Collection, an area of 2.5 m² (minimum) is required for the storage of two Blue Boxes, a Green Cart, a Garbage Container and unlimited Leaf and Yard Waste Containers. Sidewalks shall remain clear for pedestrian accessibility at all times and Waste Containers shall remain within the property line.

4. Requirements for Multi-residential Buildings

4.1 General Considerations

Ontario Regulation 103/94 requires the owner of a building that contains six or more Dwelling Units to implement a source separation program for Waste generated at the building. Multi-residential buildings are entitled to Garbage, Recycling, Organics, Bulk Waste and Leaf and Yard Waste Collection Service.

A site visit by Public Works staff is required prior to the start of Collection Service. The City, in its sole discretion, will determine Bin Container size (Appendix A), Diversion Container Requirements (Section 4.2) and frequency of Collection Service.

Collection Service will be provided by automated Front-load Bin service for Garbage, automated Blue Carts Service for Recycling and semi-automated Green Cart service for Organics in accordance with the existing Collection Service contract.

When Curbside Collection cannot be offered at a horizontal Multi-residential Building (townhouse complex) for any reason, residents must set out all Garbage, Recycling, Organics and Leaf and Yard Waste containers curbside at the property entrance. The quantity limits and set out requirements can be obtained from the Public Works Department. Potential purchasers shall be informed before purchasing the unit that Curbside Waste Collection service is not offered within the development. Any purchase, rental, or lease agreement shall contain the following declaration:

“Purchasers or tenants are advised that municipal Waste Collection Vehicles will not enter the property to collect any Waste including Garbage, Recycling, Organics, Bulk Waste and/or Leaf and Yard Waste. All Garbage, Recycling, Organics, Bulk Waste and/or Leaf and Yard Waste shall be placed curbside at the property entrance at the municipal roadway in appropriate Containers and shall comply with limits set out in the City of Hamilton Solid Waste Management By-law 09-067, as amended.”

Multi-residential buildings that are developed in such a way that will not allow

sufficient space for Collection Vehicles to enter the property and collect Waste in accordance with the Occupational Health and Safety Act (OHSA) have two options to consider;

- establish a pre-approved collection location and relocate Waste to the location for Collection Service; or
- retain a Private Waste Hauler.

4.2 Diversion Container Requirements

In order to receive Waste Collection Service, it is mandatory to participate in Waste diversion program. The following chart indicates the number of carts provided to Multi-residential Buildings.

| Number of Units | Blue Carts provided | Number of Units | Green Carts provided |
|---|---------------------|-----------------|----------------------|
| 5 or less | 0 | 1 to 15 | 1 |
| 6 to 10 | 1 | 16 to 30 | 2 |
| 11 to 20 | 2 | 31 to 45 | 3 |
| 21 to 30 | 3 | 46 to 60 | 4 |
| 31 to 40 | 4 | 61 to 75 | 5 |
| Multi-residential Buildings will typically receive 1 blue cart for every 10 units and 1 green cart for every 15 units. More carts will be provided when necessary | | | |

4.3 External Storage/ Collection Container Requirements

A site design for Blue Cart and Green Cart storage areas shall be in accordance with the following:

- a footprint to accommodate the appropriate number of carts as per the chart in Section 4.2;
- 1.0 m x 0.8 m per Blue Cart; 0.6 m x 0.5 m per Green Cart (Appendix B); and
- storage areas shall be in compliance with the *Ontario Building Code*.

The following dimensions and clearances are required (Appendix A):

- single Bin Container - clearance at the opening of 4.25 metres minimum;
- double Bin Container - clearance at the opening of 8.5 metres minimum;
- the outside gates of the enclosure shall swing open 135 degrees; and
- a minimum 9.5 metre overhead clearance is required with free and clear

overhead access preferred with no overhanging structures or utilities for Collection Vehicle operation and travel in a driveway or laneway.

All external Containers, Blue Carts and Green Carts shall be located on the property in compliance with the Property Standards By-law 10-221 and the Yard Maintenance By-law 10-118. The use of Common Collection Pads in developments will not be supported unless a condominium corporation or owner maintains the cleanliness and accessibility of the Common Collection Pad.

4.4 Internal Container Storage

Multi-residential Buildings are required to provide an on-site storage room for Waste. This storage room shall be internal, ventilated, rodent-proof and separate from the living space. The storage room shall meet all Ontario Building Code Regulations, as amended. Garbage Containers, Blue Carts and Green Carts should be placed within close proximity to one another in a clean, well lit location for easy and safe access by residents.

It is recommended that a “refuse room” be situated on each floor in order to provide residents with equal and easy access for sorting all Waste. Refuse rooms shall conform to all fire regulations. Where the building includes Waste chutes, it shall comply with the provisions of Section 24 of the City of Hamilton’s Property Standards By-law 10-221, as amended, which reads:

- 24(1) A waste storage area, including a waste chute, shall be kept clean and in a sanitary condition free from obnoxious odours.
- 24(2) Subject to 24(3), a waste chute in a building containing three (3) or more Dwelling Units shall be maintained in operation at all times.
- 24(3) A waste chute in a building containing three (3) or more Dwelling Units shall not be closed to use except when:
 - (a) such action is necessary in order to safely make repairs, replacements or alterations, and then only during the reasonable minimum time that such action is necessary; or
 - (b) (i) the owner provides a waste storage area on each floor of the building and daily collection of waste from such waste storage areas; and
 - (ii) the occupants are not required to deliver waste to the ground floor, basement or parking lot of the building.

4.5 Bin Collection Area Requirements

The collection area shall remain clear and safe for the Waste Collection Vehicles to operate efficiently. All the specifications listed in Section 2.4 Requirements for On-Site Collection on Private Property shall be met. The Bin Container cannot exceed 6.12 m³ for loose Garbage and 2.3 m³ for compacted Garbage (Appendix A).

4.6 Maintenance Requirements for Access

Access/Private Roads shall be maintained at all times and provide acceptable pavement conditions for Waste Collection Vehicles and staff. Maintenance activities include but are not limited to snow removal, pot-hole repair and crack sealing.

5. Requirements for Eligible Institutional & Municipal Developments

5.1 Places of Worship

Places of worship will be provided with Garbage, Recycling, Organics, Bulk Waste and/or Leaf and Yard Waste Curbside Collection Service. However, any ancillary buildings are not entitled to Waste Collection Service.

5.2 Schools

Elementary and Secondary schools will receive Recycling and Organics Collection Service provided that a service agreement has been established between the City and the school board. The collection of all other Waste shall be through a Private Waste Hauler.

Site design for Recycling and Organics Collection area shall:

- accommodate a Bin Container for fibre materials;
- accommodate a minimum of two Blue Carts, with dimensions of 1.0 m x 0.8 m per Cart;
- accommodate a minimum of one Green Cart, with dimensions of 0.6 m x 0.5 m; and
- be exclusive of any on-site parking and play areas on the site.

The following dimensions and clearances are required to accommodate a Bin Container for fibre material (Appendix A):

- single Bin Container - clearance at the opening of 4.25 metres minimum;
- double Bin Container – clearance at the opening of 8.5 metres minimum;
- the outside gates of the enclosure shall swing open 135 degrees; and
- free and clear overhead access with no overhanging structures or utilities is preferred; a minimum 9.5 metres overhead clearance is required for Collection Vehicle operation.

All external Containers, Blue Carts and Green Carts shall be located on the property in compliance with the Property Standards By-law 10-221, as amended, and the Yard Maintenance By-law 10-118.

The following note shall appear on the site plan for any school defined as an Eligible Property for Collection Service:

"This property is eligible for municipal collection of Recyclable Material through the City of Hamilton, providing that a Recycling service agreement is in place and subject to compliance with specifications indicated by the Public Works Department."

The following note shall appear on the site plan for any school defined as an Ineligible Property for Collection Service:

"This property is ineligible for municipal collection of Garbage, Recycling, Organics and Leaf and Yard Waste through the City of Hamilton. Waste Collection Service shall be arranged with a Private Waste Hauler(s)."

5.3 Municipally Owned or Leased Properties

The City strongly encourages any Municipal Building developments to be designed to support the City's Waste diversion programs. Requirements for any developments shall stipulate the appropriate type, quantity and location of Waste Collection containers.

The best location for Waste container can be identified by finding a balance between convenience to users, space, access, planning requirements and architectural integration. The following should be considered during the design and development process:

- Recycling storage should be located with or adjacent to the Garbage storage. However, Garbage and Recycling containers should be kept separated and not intermingled;
- containers should not block or impede any fire exits, public right-of-ways or pedestrian traffic and vehicular access; and

- Waste storage should be located at ground level and adjacent to the area where Collection Vehicles are allowed to access the facility.

Developers or owners shall take into consideration the following factors while determining the size and location of Waste storage:

- building use;
- building occupancy;
- quantities of waste generated by occupants;
- extra storage capacity;
- space allowance for users to access and manoeuvre around containers; and
- potential changes to Waste Collection programs.

The following note shall appear on the site plan for Municipal Buildings:

“This municipal owned or leased property is eligible for Collection Service of Garbage, Recycling, Organics, Leaf and Yard Waste subject to continuous compliance with the City’s Solid Waste Management By-law 09-067, as amended and the Solid Waste Collection Design Guidelines for Developments. Recycling and Organics diversion is mandatory.”

6. Requirements for Other Properties

6.1 Mixed Use Commercial/Multi-residential Buildings with six (6) or More Residential Units

Collection Service for mixed use commercial/Multi-residential developments shall:

- follow the established Waste Collection Service guideline for the predominant use of the building;
- obtain a Private Waste Hauler if Municipal Waste Collection is not available; and
- include storage areas that are designed in accordance with the requirements set out in Section 4. Requirements for Multi-residential Building.

6.2 Commercial Properties with a Maximum of Three (3) Floors & Commercial Properties in Special Policy Areas

Collection Service for commercial properties with three (3) or less floors in Special Policy Areas (as defined in ‘Urban Hamilton Official Plan’ Vol. 3-C) shall:

- be provided Curbside Collection of Garbage, Recycling, Organics, Leaf and Yard,

- and Bulk Waste; and
- include storage areas that are designed in accordance with the requirements set out in Section 3. Requirements for Residential Properties with a Maximum of Five (5) Units.

6.3 Industrial Developments, Shopping Centres, Commercial Properties with Four (4) Floors or More & Institutions

The collection of Garbage, Recycling, Organics, Leaf and Yard, and Bulk Waste is required through a Private Waste Hauler. Recycling and Organic Waste diversion is strongly encouraged.

7. Commencement of Collection Service

The City approves Collection Service subsequent to the development planning approval process. Comments are provided for each Development Application based on these design guidelines and By-law 09-067 as amended, in order to enable a developer or owner to meet the requirements for receiving Collection Service. Development Applications which are approved but do not meet the requirements set out in this document or in the By-law will not be eligible for Collection Service.

Before commencement of any Collection Service:

- the developer or owner shall contact the City of Hamilton by email wastemanagement@hamilton.ca or by telephone 905-546-CITY(2489) to notify the City that the site is Substantially Completed and that there is free, clear and safe access for Waste Collection Vehicles and operators;
- Public Works staff will complete a site visit; and
- for Collection Service on Private Roads, a Private Road Application and Agreement shall be submitted to the City.

The City shall, in its sole discretion, determine Collection Service for the development including the weekly collection day(s) and anticipated start date for the services.

Appendix A: Bin Container Specifications

Bin Container Sizes for Multi-residential Garbage

The guidelines noted below are for estimates and do not necessarily reflect every situation.

| Bin Type/Bin Size | 3 cubic yard | 4 cubic yard | 6 cubic yard |
|-------------------|--------------|---------------|---------------|
| Compacted | 88 units/bin | 117 units/bin | 176 units/bin |
| Uncompacted | 30 units/bin | 40 units/bin | 60 units/bin |

Bin Container Dimensions

3 cubic yard bin

Width 180cm (71")
Depth 104cm (41")
Height 122cm (48")

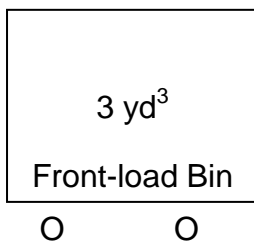

4 cubic yard bin

Width 180cm (71")
Depth 150cm (59")
Height 122cm (48")

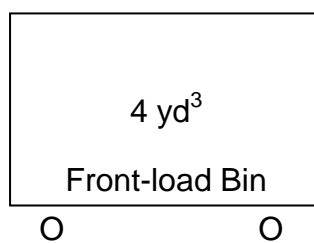

6 cubic yard bin

Width 180cm (71")
Depth 180cm (71")
Height 145cm (57")

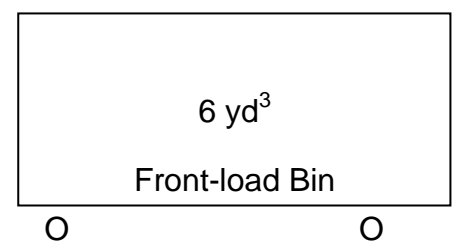

Garbage Enclosure Specifications

- Outside gates of the enclosure swing open 135 degrees
- Single Front-load Bin Container minimum clearance at the opening is 4.25 m
- Double Front-load Bin Container minimum clearance at the opening is 8.5 m

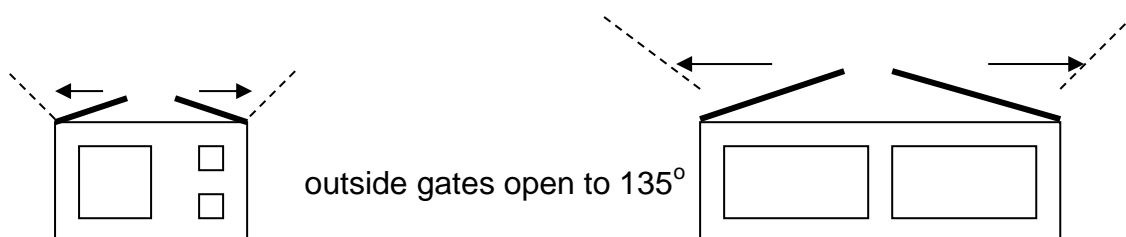

Appendix B: Blue & Green Cart Dimensions

BLUE CART DIMENSIONS

Recycling container for Multi-residential buildings

Side view - Depth 89 cm (35")

Front view - Width 61 cm (24")



Height - 109cm(43")

GREEN CART DIMENSIONS

Organics container for Multi-residential buildings

Side view - Depth 55 cm (22")

Front view - Width 48 cm (19")



Height 93 cm (37")

Appendix C: "T" Turnaround Specifications



Appendix 3

"T" Turnaround Specification

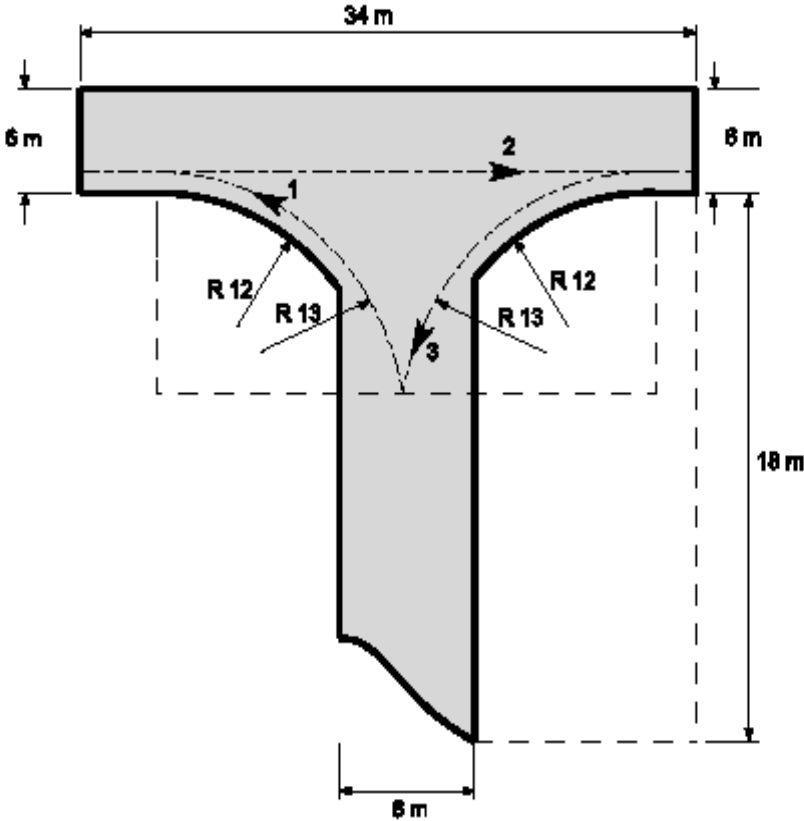

Note: All dimensions are in metres
Not to scale

Appendix D: Private Road Application

Ver.1-2015



Hamilton

Public Works Department

| | |
|---|--------------------------|
| FOR OFFICE USE ONLY – Application No.: | |
| New Application | <input type="checkbox"/> |
| Amended Application | <input type="checkbox"/> |
| Amended Application/Change of Ownership | <input type="checkbox"/> |
| PIN Printout(s) Provided | <input type="checkbox"/> |

APPLICATION FOR ON-SITE COLLECTION OF MUNICIPAL SOLID WASTE

| | | | |
|---|--------------------------|-----------------------------------|--|
| Applicant (if not the Current Owner of the Property, also explain relationship of Applicant to the Current Owner of the Property): | | Current Owner of Property: | |
| Address of Current Owner: | City: | Postal Code: | |
| Email Address: | Telephone Number: | Fax Number: | |
| Signature: _____ Date: _____ (Year/Month/Day) | | | |
| I, the Applicant, am the Current Owner of the Property or I represent and warrant that I have the authority to act on behalf of the Current Owner(s) of the Property and to bind the Current Owner(s) of the Property regarding this Application. I also represent and warrant that the information contained in this Application is accurate. I understand that the Current Owner(s) of the Property will be required to sign the resulting Agreement for On-Site Collection of Municipal Solid Waste if approved by the City of Hamilton. | | | |

COLLECTION IS REQUESTED AT THE FOLLOWING PROPERTY:

| | |
|--|--|
| Address: | Property Name (if applicable): |
| Building Contact Person: | Contact Telephone Number: |
| Building Type: <input type="checkbox"/> Vertical Multi-Residential <input type="checkbox"/> Horizontal Multi-Residential <input type="checkbox"/> Other: _____ | (If Applicable) Number of floors: Number of units: |
| (If Applicable) Number and size of garbage containers: _____ Number of pick-up locations at above property: _____ Number and size of waste enclosures on site: _____ | |

Notice of Collection of Personal Information under the Municipal Freedom of Information and Protection of Privacy Act (MFIPPA)

The personal information on this Application Form is collected under the authority of the Municipal Act, 2001, S.O. 2001, c.25, as amended. The information collected will be used for the purpose of administering the City of Hamilton's on-site collection of municipal solid waste under the City of Hamilton's Solid Waste Management By-law No. 09-067, as amended. Questions about this collection should be directed to the Policy/Program Analyst, Operations Division at 905-546-2489, ext. 5252 during the hours of 8:30 a.m. to 4:30 p.m., Monday through Friday.

FOR OFFICE USE ONLY

| | | |
|---|---|---|
| Roll Number: | Date Application Received: | Application Reviewed By: |
| Service Required: <input type="checkbox"/> Front-End Garbage Container Service <input type="checkbox"/> On-site Garbage Collection Service <input type="checkbox"/> Front-End Fiber Bin Service <input type="checkbox"/> On-site Recycling Collection Service <input type="checkbox"/> Recycling Cart Service <input type="checkbox"/> On-Site Organics Collection Service <input type="checkbox"/> OTHER | | |
| Collection Zone: | Garbage Collection Day: Recycling Collection Day: Organics Collection Day: | |
| Garbage Service Start Date: | Recycling Service Start Date: | Organics Service Start Date: |
| Number and Size of Garbage Containers: | Number and Size of Recycling Carts: | Number and Size of Organics Carts: |
| Ownership Verified: Comments: | | |



Hamilton

Public Works Department

**AGREEMENT FOR ON-SITE COLLECTION OF
MUNICIPAL SOLID WASTE**

In consideration for the provision of *On-Site Collection Services* (as herein defined), the *Current Owner* (as herein defined) agrees as follows:

ARTICLE 1 – DEFINITIONS

Access Area is the lane, street, avenue or other means of ingress or egress available for the *City* and/or *Contractor* to access the *Collection Area* and includes adequate space for the *City* and/or *Contractor* to perform vehicle turnaround functions, as well as pick-up functions, safely.

Agreement means this Agreement for On-site Collection of Municipal Solid Waste and includes the *Application* and Schedule “A” hereto. In the event of conflict between the *Application*, Schedule “A” and the body of this *Agreement*, the body of this *Agreement* shall apply and prevail.

Application means an application in a form prescribed by the *City*, completed by the *Current Owner* with respect to each *Property* for the provision of *On-Site Collection Services* and approved by the *City*. Each approved *Application* shall form a part of this *Agreement*, even though it is not physically attached hereto.

Business Day means any day other than a Saturday, Sunday, public holiday or other day on which banks in Ontario are authorized or required by law to be closed or any other day where the administrative offices of the *City* are closed.

City means City of Hamilton.

Collectible Waste means waste, including organic waste and recyclable materials and any other solid waste materials acceptable for pick-up in accordance with the *Solid Waste By-Law*, and which are identified for pick-up in Schedule “A” attached hereto for each *Property*.

Collection Area means an area provided by the *Current Owner* where *Collectible Waste* will be placed for pick-up by the *City* and/or its *Contractor(s)* for each *Property*, as approved by the *City*.

Contractor means any individual or entity employed or contracted by the *City* to provide *On-site Collection Services*.

Current Owner means the individual(s) or entity(ies) that holds title to the *Property* or *Properties*; or in the case of a condominium, the condominium corporation responsible for the *Property* or *Properties*; as at the date of execution of this *Agreement*. Where there is more than one individual or entity that holds title to the *Property* or *Properties*, they shall be jointly and severally liable for the liabilities and obligations of the *Current Owner* under this *Agreement*.

Former Contracts and Indemnities means any contract(s) and/or indemnity(ies) entered into between an *Owner* and any of the *Former Municipalities*, or with the *City*, with respect to *On-Site Collection Services*, whether or not said contract(s) and/or indemnity(ies) was/were, or is/are, registered on title.

Former Municipalities means those municipalities that were dissolved pursuant to the *City of Hamilton Act, 1999, S.O. 1999, CHAPTER 14, Schedule C*, when the *City* was established.

On-Site Collection Services means the non-curbside/roadside collection of *Collectible Waste* by the *City* and/or a *Contractor* from the *Collection Area* of each *Property*, including ingress and egress to/from each *Property* via the *Access Area*.

Owner means any individual(s) or entity(ies) who had, has, or will have title to any property, or in the case of a condominium, the condominium corporation who had, has, or will have responsibility for a property, for which *On-Site Collection Services* was, is, or will be requested.

Property means a property owned by the *Current Owner* executing this *Agreement* for which the provision of *On-Site Collection Services* has been, or is being, requested, as set out in Schedule “A” attached hereto. All *Properties* requiring *On-Site Collection Services*

Services by the *Current Owner* shall be listed in Schedule “A” with the corresponding *Collectible Waste* requirements and *Application* number for each *Property*.

Solid Waste By-law means the City of Hamilton’s Solid Waste Management By-law No. 09-067, as amended and as it exists from time to time, or any successor by-law.

ARTICLE 2 – CURRENT OWNER RESPONSIBILITIES

2.1 General

2.1.1 The *Current Owner* hereby agrees to provide an unobstructed *Collection Area* and *Access Area*, which shall be easily accessible to the *City* and/or its *Contractor(s)*, for the provision of *On-Site Collection Services* for each *Property*. This includes, but is not limited to, a safe, unobstructed *Access Area* and *Collection Area*, an adequate vehicle turning area, as well as reasonable snow and ice removal in the *Access Area* and *Collection Area*.

2.1.2 The *Current Owner* hereby agrees to provide waste containers approved by the *City* in accordance with the *Solid Waste By-Law* for each *Property*.

2.1.3 The *Current Owner* hereby agrees that the *Collectible Waste* to be collected through the provision of *On-Site Collection Services* by the *City* and/or its *Contractor(s)* for each *Property* is set out in Schedule “A” of this *Agreement*.

2.1.4 The *Current Owner* hereby undertakes to advise all tenants and unit owners for each *Property* of the existence of this *Agreement* and to provide a copy of this *Agreement* to a tenant or unit owner upon request.

2.2 Insurance

2.2.1 Throughout the term of this *Agreement* (including any renewal thereof), the *Current Owner* shall obtain and maintain at its own expense, including the cost of any applicable deductible, Commercial General Liability Insurance, covering the *Property* or *Properties* identified in Schedule “A” of this *Agreement* and written on IBC Form 2100 or its equivalent, including but not limited to bodily and personal injury liability, property damage, and premises liability coverage, having a minimum, inclusive limit of not less than \$2,000,000.00 per occurrence and \$4,000,000.00 in the aggregate. The policy shall be endorsed to include the *City* of Hamilton and its *Contractors* as additional insureds, but only with respect to liability arising out of this *Agreement*.

2.2.2 The *Current Owner* shall deposit with the *City* a Certificate of Insurance originally signed by an authorized insurance representative and confirming thereon relevant coverage information at the time of execution of this *Agreement* and thereafter during the term of this *Agreement*, at the request of the *City*. The certificates of insurance shall contain a provision that the insurer shall not cancel, or materially change coverage as would affect this *Agreement* without providing the *City* at least thirty days prior written notice. Certificate Holder will be addressed as the *City* of Hamilton, City Hall, 71 Main Street West, Hamilton, Ontario L8P 4Y5 Attention: Policy/Program Analyst, Operations Support, Operations Division, Public Works Department. All certificates, cancellation, nonrenewal or adverse change notices are to be mailed to this address. All insurers shall be licensed to do business in Ontario and such insurance policy wording and terms shall be acceptable to the *City*. All insurance coverage to be provided by the *Current Owner* in this *Agreement* shall be primary and not call into contribution any other insurance coverage available to the *City*. The *Current Owner* shall not do or omit to do anything that would impair or invalidate the insurance policies. The required insurance described herein may be altered or increased by the *City*, acting reasonably.

2.3 Indemnity

The *Current Owner* hereby agrees to defend, release and forever indemnify and save harmless the *City*, its officers, directors, employees, officials, agents and its *Contractor(s)* (collectively the “Indemnitees”), of and from any claims, demands and/or causes of action that may arise by reason of, or in connection with, the operation of collection vehicles, or personnel, or the work of the Indemnitees on any *Property*, *Collection Area* or *Access Area*, or any combination of the foregoing, resulting, directly or indirectly, in damages (including special or consequential damages), loss, costs, fines, penalties, and/or injury to person(s)

3.2 Term of Agreement

This *Agreement* shall come into effect as of the date of execution by the *Current Owner* and shall remain in force until,

- (a) it is terminated by the *Current Owner* by providing no less than 10 *Business Days* prior written notice to the *City*, or
- (b) the *City* discontinues the *On-Site Collection Services* for a *Property*, or
- (c) this *Agreement* is otherwise terminated in accordance with the provisions of this *Agreement*.

No amendments to this *Agreement* shall be effective without the prior written consent of the *City*.

3.3 Nature of Agreement

The *Current Owner* acknowledges and agrees that this *Agreement* is the *City's* standard agreement for *On-Site Collection Services* and shall govern the entire relationship between the *City* and the *Current Owner*. This *Agreement* shall supercede and replace any and all *Former Contracts and Indemnities*. Should the *City* change the form of this *Agreement*, the *Current Owner* agrees to execute any new agreement provided by the *City* for the provision of *On-Site Collection Services* ("New Agreement"). Should the *Current Owner* fail to execute the New Agreement within 15 *Business Days* of receipt of the New Agreement, *On-Site Collection Services* shall terminate at no cost, liability or penalty to the *City* whatsoever. Upon execution of the New Agreement, or upon the failure of the *Current Owner* to execute the New Agreement within the stipulated timeframe, this *Agreement* shall terminate at no cost, liability or penalty of any kind whatsoever to the *City*.

3.4 Successors and Assigns

This *Agreement* shall be binding on the executors, heirs, and legal representatives of the *Current Owner*. The *Current Owner* shall not assign this *Agreement*. Any attempt to assign this *Agreement* or any of the *Current Owner's* rights, duties, liabilities or obligations under this *Agreement* is void.

3.5 Fees

The *Current Owner* acknowledges and agrees that the *City* is providing *On-Site Collection Services* in consideration for the insurance and indemnities provided in this *Agreement*. As a result, the *Current Owner* understands and agrees that there are no fees and charges payable by the *Current Owner* to the *City* with respect to the provision of *On-Site Collection Services* by the *City* and/or its *Contractor(s)* pursuant to this *Agreement*.

3.6 Laws

- (a) This *Agreement* shall be governed by the laws of the Province of Ontario and the laws of Canada as applicable therein. The *Current Owner* irrevocably submits and attorns to the exclusive jurisdiction of the court of the Province of Ontario. Any action or proceeding relating to this *Agreement* shall be brought in a court of competent jurisdiction in Hamilton, Ontario.
- (b) All provisions in the *Solid Waste By-law* governing *Collectible Waste* collection shall apply, with necessary modifications to *On-Site Collection Services*, including but not limited to provisions governing when and how *Collectible Waste* can be set out for collection. In the event of a conflict between the provisions of this *Agreement* and the provisions of the *Solid Waste By-law*, the provisions of this *Agreement* prevail.

3.7 Notice

Any notice under this *Agreement* shall be sufficiently given if given by:

- (a) personal delivery; or
- (b) registered letter, postage prepaid, and mailed in a Canadian post office; or
- (c) fax;

| | |
|---|--------------------------------|
| If to the <i>City</i> | If to the <i>Current Owner</i> |
| Policy/Program Analyst, Operations Division Public Works Department, City of Hamilton City Hall, 71 Main Street West Hamilton, Ontario L8P 4Y5 Fax No. 905-546-3972 | |

or to any address as may be designated in writing by the *City* or the *Current Owner* in accordance with this provision. The date of receipt of any notice shall be deemed conclusively given on the day it was received by personal delivery, at the beginning of business on the third *Business Day* after it was mailed by registered mail or on the day sent by fax if sent on or before 4:30 p.m. on a *Business Day* of the receiving party and on the next *Business Day* of the receiving party if sent by fax after 4:30 p.m.

3.8 Independent Legal Advice

The *Current Owner* hereby acknowledges and agrees that the *City* has provided him/her/it with a reasonable opportunity to seek independent legal advice with respect to this *Agreement* and has encouraged him/her/it to do so. The *Current Owner* hereby acknowledges and agrees that he/she/it either has sought said advice or has declined to do so.

INSERT NAME OF CURRENT OWNER

WITNESS

Signature of Current Owner

Signature of Witness

Name (please print)

Name of Witness (please print)

Title (please print)

Address of Witness (please print)

Date

Date

Signature of Current Owner

Signature of Witness

Name (please print)

Name of Witness (please print)

Title (please print)

Address of Witness (please print)

Date

Date

I/We have the authority to bind the *Current Owner*

SCHEDULE "A"

LIST OF PROPERTIES AND COLLECTIBLE WASTE

| Property (Address) | PIN No. | Collectible Waste | Application No. | Effective Date |
|---------------------------|----------------|--|------------------------|-----------------------|
| | | Services defined in Solid Waste Management By-Law 09-067 | | |